

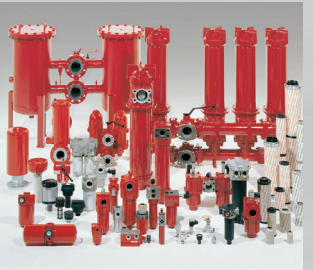

Accumulator Technology 30.000



Filter Technology 70.000



Process Technology 77.000



Filter Systems 79.000

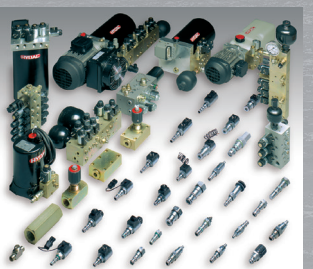

Compact Hydraulics 53.000



Accessories 61.000



Electronics 180.000



Cooling Systems 57.000

Global Presence.  
Local Expertise.  
[www.hydac.com](http://www.hydac.com)

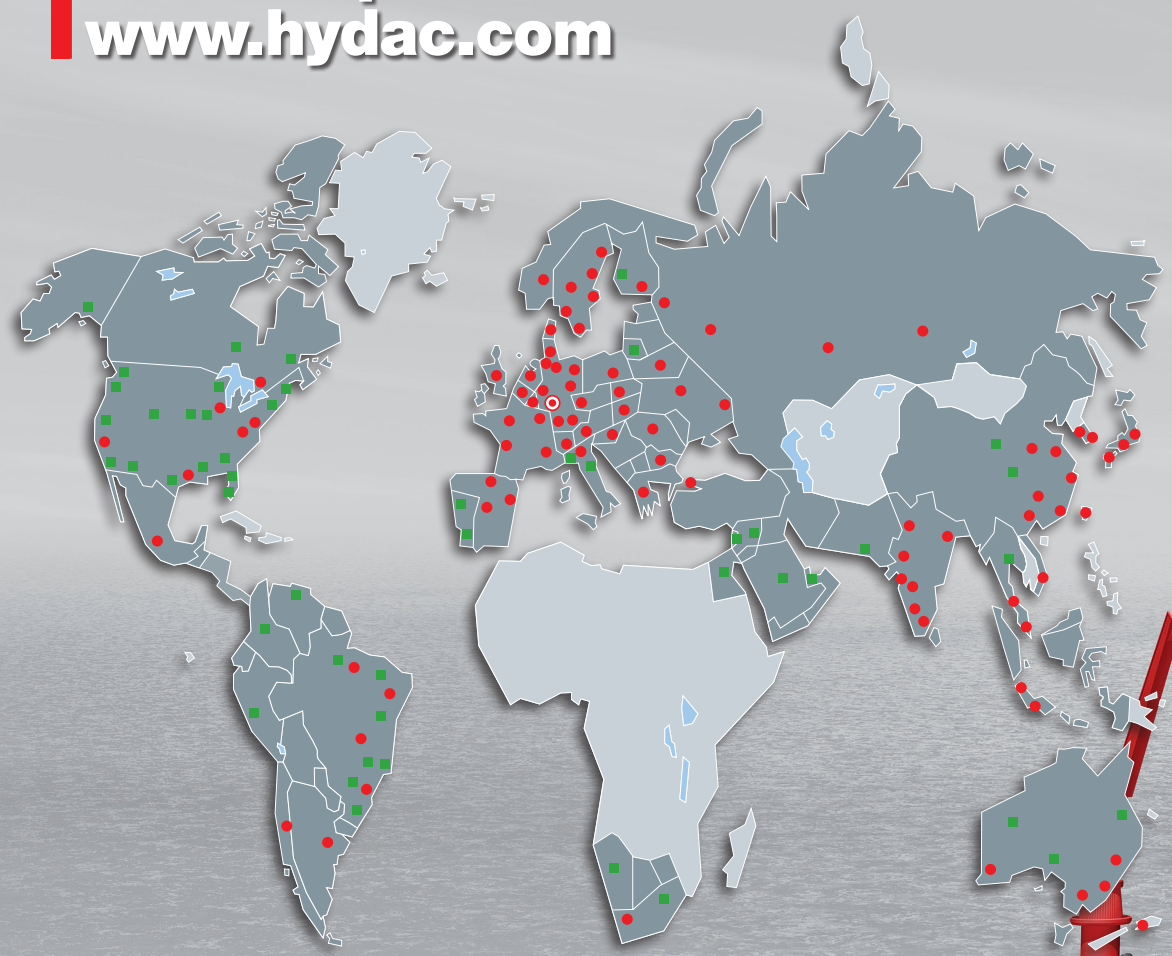

- HYDAC Headquarters
- HYDAC Companies
- HYDAC Sales and Service Partners

# HYDAC INTERNATIONAL

## Hydraulic Cylinders for Marine Applications

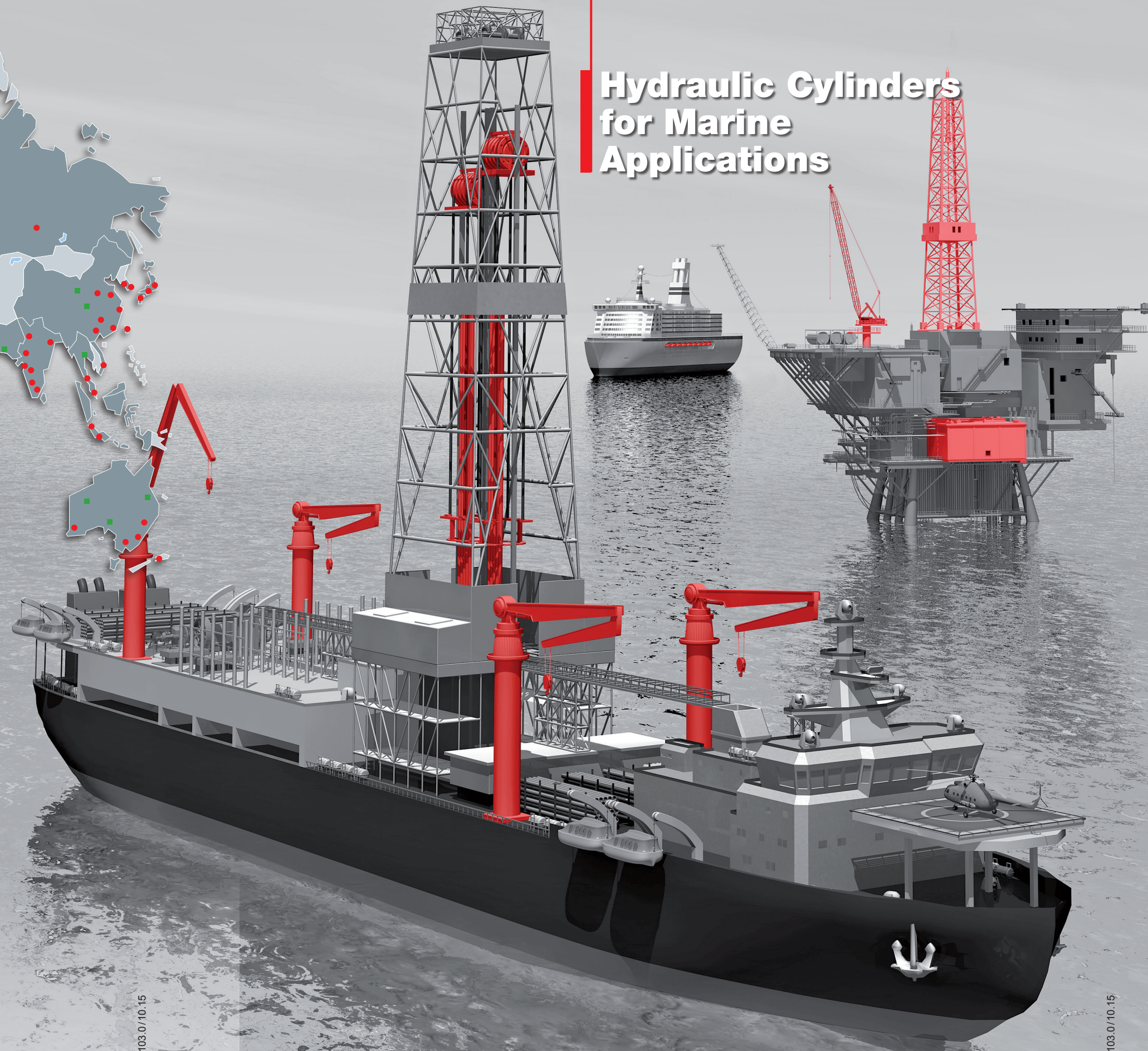

**HYDROSAAR**  
HYDAC INTERNATIONAL

**Contact**  
HYDAC INTERNATIONAL  
GMBH

Hirschbachstraße 7  
66280 Sulzbach/Saar  
Germany

Tel.: +49 6897 509-9700  
Fax: +49 6897 509-9791

E-mail: [info@hydrosaar.de](mailto:info@hydrosaar.de)  
Internet: [www.hydac.com](http://www.hydac.com)

HS-E 10\_103.0/10.15

HS-E 10\_103.0/10.15

# Your Partner for Expertise in a Wide Variety of Marine Applications

## Overview

Control / Safety

Special Vessels

Deck Superstructure

Technical Information

Additional Solutions

### Control / Safety

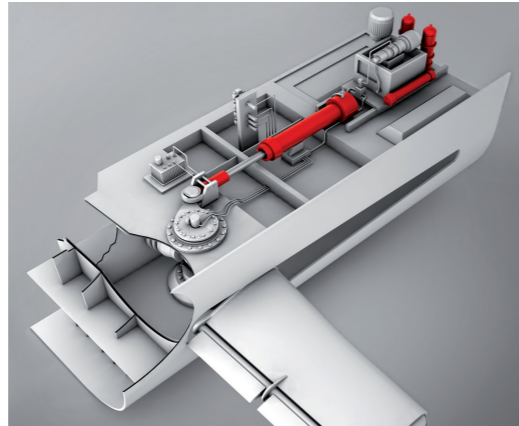

**Cylinders for the steering, control and operational safety of ships and platforms**

- Fin stabilisers
- Retractable thruster function
- Rudder adjustment
- Hatch closure
- Heave compensation

### Special Vessels



**Special applications for various types of vessel**

- Jack-up vessels
- Pipe-laying vessels
- Split hopper barges
- Dredgers
- Trailing suction hopper dredgers

### Deck Superstructure

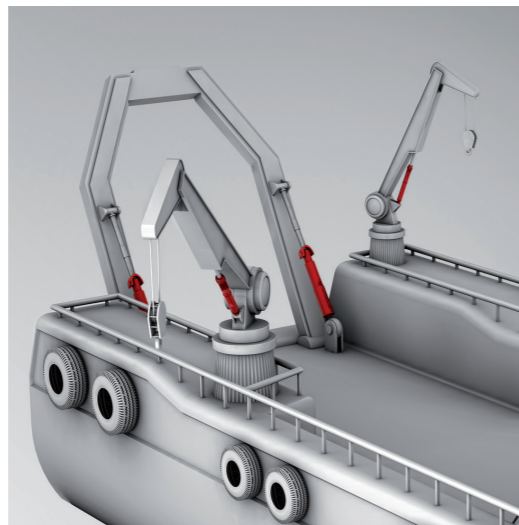

**Cylinders for a wide variety of deck superstructure tasks**

- Davit system
- Opening cylinders
- A-frames
- Roll-on / roll-off loading system

### Technical Information



**The perfect solution for any environmental condition**

- Classification of the environmental conditions
- Suitable bar stock and rod coatings
- Cylinder model code

### Additional Solutions



**We make your hydraulic system complete - with HYDAC components and systems:**

- Accumulators and filters
- Pumps and cooling solutions
- Mounting technology and pipe connections
- Ball valves and fittings
- Fluid conditioning systems
- Sensors
- Control technology
- Condition Monitoring, Teleservice



# Hydraulic Cylinders for Marine Applications

## Reliable Service Life under Extreme Conditions

### Components and Systems of Certified Quality



Hydraulic components in shipping require high reliability of the drive and safety systems as well as minimal downtimes, even under extreme environmental conditions.

**HYDAC/HYDROSAAR** has the technical know-how and many years of experience in the development and manufacture of high-quality hydraulic cylinders for marine applications – proven by our certifications and worldwide approvals.

#### HYDAC/HYDROSAAR offers:

- Customised solutions for a wide range of requirements and local conditions, e.g. for cruise ships, working ships, freighters, container ships and pontoons, etc.
- Special coatings for piston rods that must be corrosion resistant in saline environments
- State-of-the-art technology, functionality and the highest level of safety, as well as ATEX versions
- Worldwide service and general overhauls
- Supplementary components and systems for sensor and valve technology
- Fully integrated position measuring systems
- Optional proximity sensors and pressure sensors for integration into the cylinders
- Internal/external accumulator solutions
- Energy-efficient systems

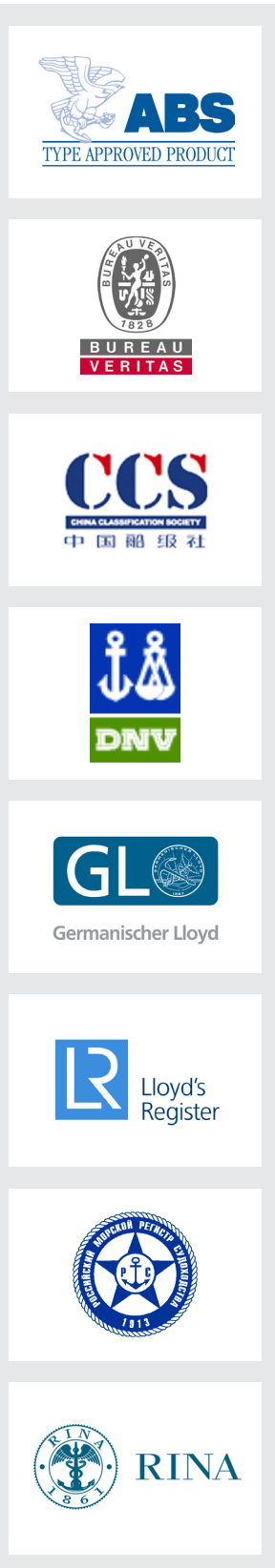

# We Provide Support Throughout the Process Chain

## Innovative Solutions from an Expert Source

### Expertise in Development, Manufacturing and Service

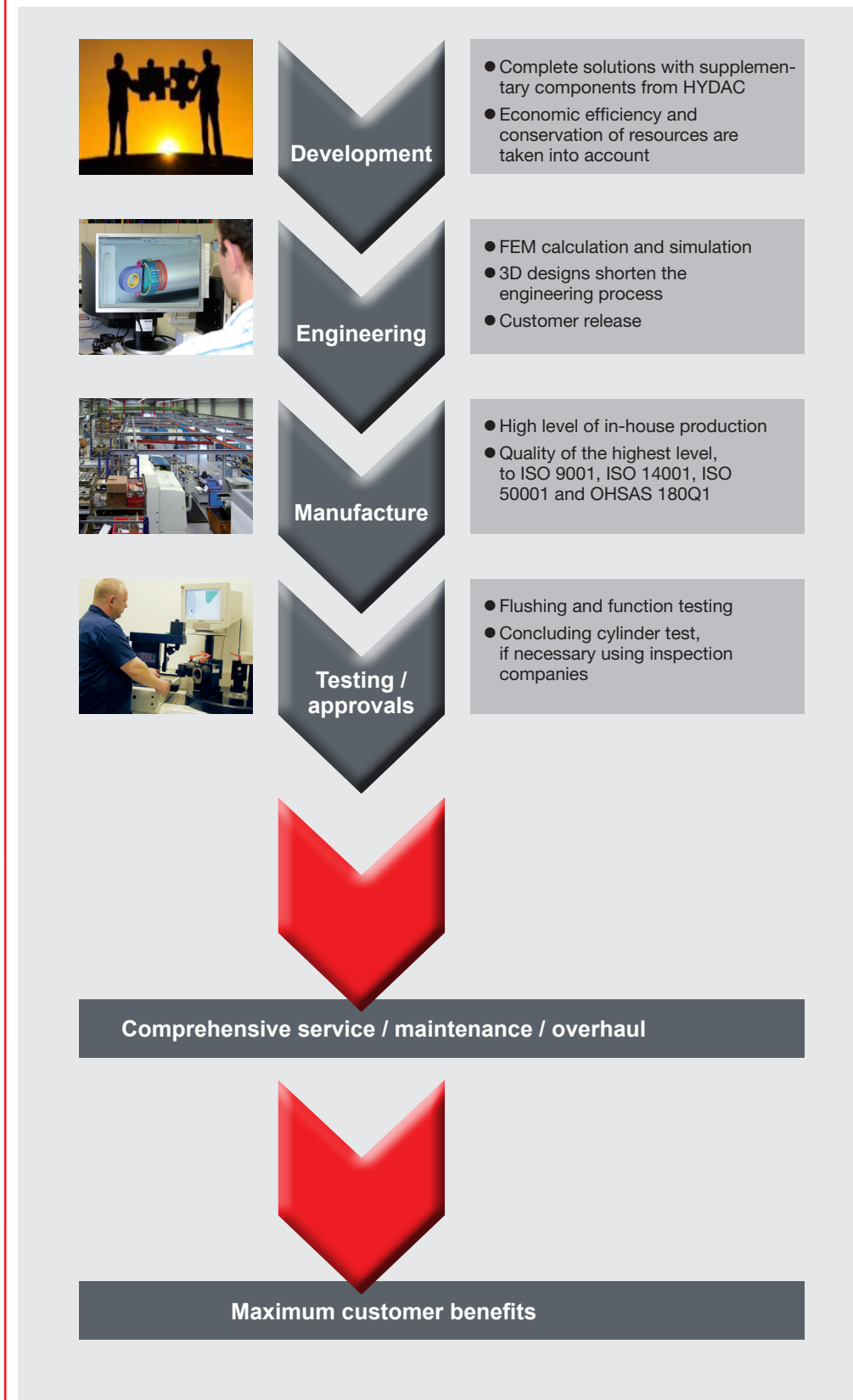

# Control of Motion Sequences

## Reliable Solutions for Specific Tasks

### Fin Stabilisers

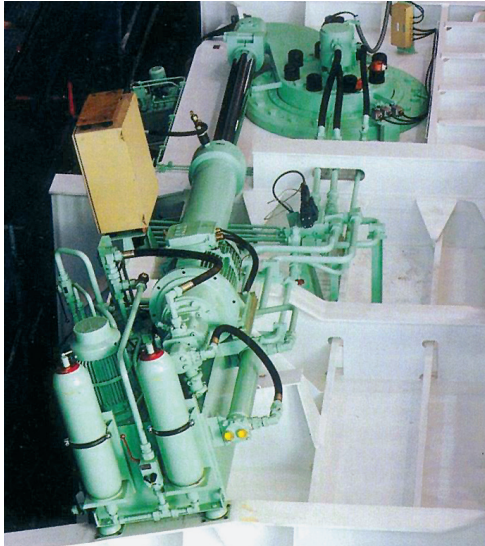

Stabilisers reduce the motions of a ship which are caused by wind and swell. They do so by counterbalancing rolling movements about the longitudinal axis.

To avoid the worst-case scenario - capsizing of the ship - the stabilisers prevent the load from shifting as much as is possible.

The fins on the ship's hull, which can be positioned hydraulically thanks to a cylinder, straighten up the ship using the pressure of the water flow.

- Cylinder 180/125 – stroke 1,200 mm

### Retractable Thruster Cylinders

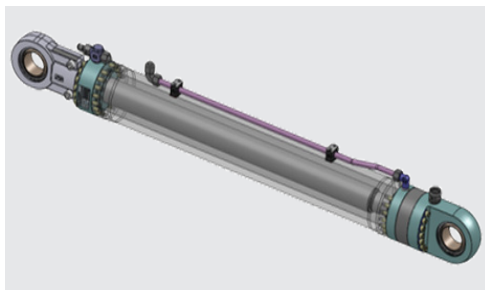

Differential cylinder with safety valve technology

In certain kinds of ships, the propellers are located up to six metres under water to improve navigation. In shallow water the drive propellers need to be raised and our hydraulic cylinders make this possible. With this system, ships are able to navigate even shallow waters.

- Cylinder 330/240 – stroke 3,000 mm

### Rudder Cylinders

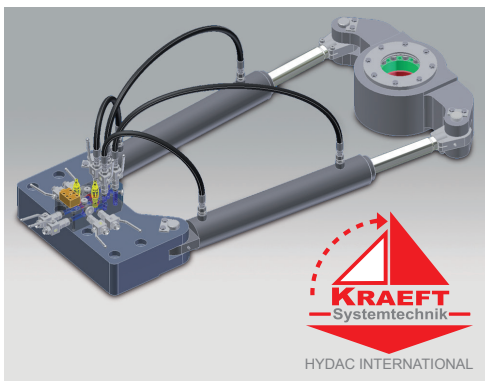

Steering ships requires moveable rudders, which can be moved using our hydraulic cylinders. They are one of the final links in the chain, and shift the rudder to the left or the right, which steers the ship.

Our robust cylinders offer maximum manoeuvrability and optimal effectiveness.

- Cylinder 125/70 – stroke 1,800 mm

### Hatch Covers



The ship's deck hatches must be air and watertight when closed so that goods on board the ship can be protected from marine weather conditions.

Our hydraulic cylinders guarantee precise opening and closing of the hatches.

- Cylinder 300/250 – stroke 5,400 mm

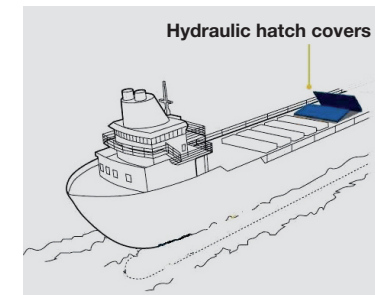

### Heave Compensation



Heave compensation systems are used on deck cranes to neutralise the movements of a vessel. No fixed reference point is needed for this process in the case of Active Heave Compensation (AHC). Instead, a Motion Reference Unit (MRU) compensates for the swell by measuring roll, pitch and yaw motions.

This active hydraulic system consists of piston accumulator and cylinder which are coupled to each other.

In this example, piston accumulators with a size of 1,000 litres and a cylinder stroke of 4,500 mm are fitted.

- Cylinder 630/220 – stroke 4,500 mm



# Cylinders for Special Vessels

## Specific Developments for Every Application

### Jack-Up Vessels



Jack-up vessels are required to build offshore wind farms. They are equipped for this by a heavy-duty crane and their own drive. They are also fitted with lifting equipment so they can operate in rough seas. Between four and six hydraulically operated "legs", which are raised during travel, support the vessel in the jack-up position where they are lowered onto the sea bed. The ship can then be used as a work platform.

Multiple cylinders per leg can be installed for the hydraulic movements.

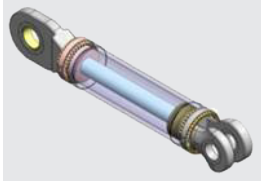

● **Cylinder 700 / 400 – stroke 7,900 mm**

### Pipe-Laying Vessels



These are working ships which are used to lay pipes on the sea bed for transporting oil and gas. On board the ship the pipes are welded together to form a pipeline.

There are two methods for laying pipes used by these vessels: **S-Lay** (for low and medium water depths): pipeline segments are welded together and laid in a horizontal position.



● **J-Lay** (for great water depths): pipeline segments are welded together in a horizontal position and then laid in a vertical position.

● **Cylinder 300 / 180 – stroke 800 mm**

### Split Hopper Barges



Split hopper barges are used for land reclamation. They transport sediments such as sand, stone and clay which are then unloaded, either at sea, in rivers or in coastal areas, by the hull of the barge splitting into two halves.

Hinges allow these two halves to rotate in opposite directions. On both halves the hinges are connected to hydraulic cylinders.

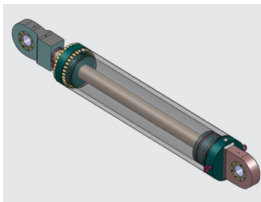

● **Cylinder 320 / 180 – stroke 1,500 mm**

### Dredgers



Dredgers are used when cleaning canals and rivers, to consolidate and construct shorelines, and for infrastructure work/landscaping/foundation work.

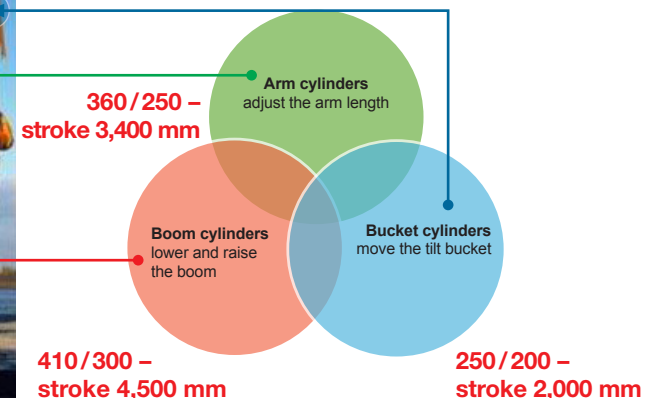

### Cutter Suction Dredgers

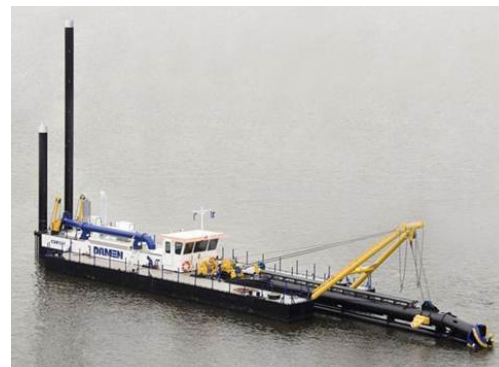

The underwater cutter head is controlled by a cylinder. A system is used which comprises a hydraulic cylinder with valve block and integrated position measuring system.

● **Cylinder 360 / 280 – stroke 8,300 mm**

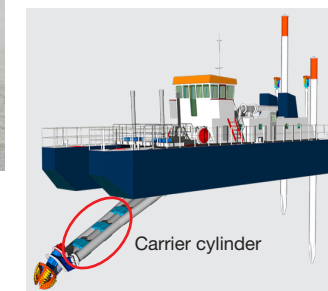

### Trailing Suction Hopper Dredgers



Trailing suction hopper dredgers primarily remove dredged material (solid materials such as sand, gravel, etc.) from the ocean floor by means of an extendable suction pipe, drag head and slow forward movement. The water content is separated off and deposited back into the sea.

These vessels need to be capable of many different movements and so the hydraulic requirements are very complex.

# Cylinders for Deck Superstructure

## Safe and Reliable Movements

### Cranes



To ensure safe and precise loading and unloading of ships, we offer standard hydraulic cylinders adapted to marine conditions as well as customised solutions for deck cranes.

- **Cylinder 250/200 – stroke 3,300 mm**

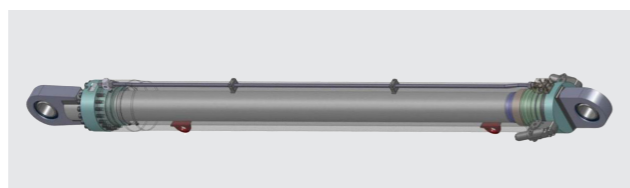

### Davit Systems for Lifeboats



A davit is a crane installed near the side of a ship for lowering or raising lifeboats. Cylinders with integrated valve technology provide these functions, which must be reliably guaranteed in case of an emergency. The cylinders are individually designed depending on the load requirement.

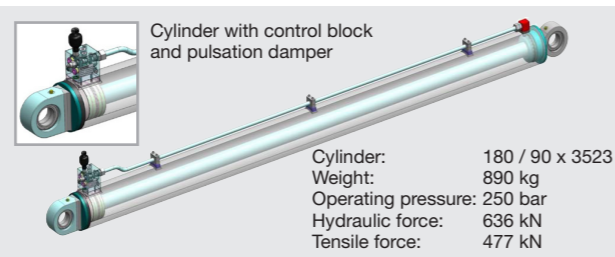

### Opening Cylinders



In container ships, ferries and also yachts, opening cylinders are used to open and close doors and gates. For safety reasons, our opening cylinders are equipped with a locking function that automatically closes the doors when the pressure drops.

These cylinders are compact and space-saving to accommodate the space limitations on board. And because no two ships are the same, we adapt our opening cylinders to the specific conditions.

- **Cylinder 300/250 – stroke 4,200 mm**

### A-Frames

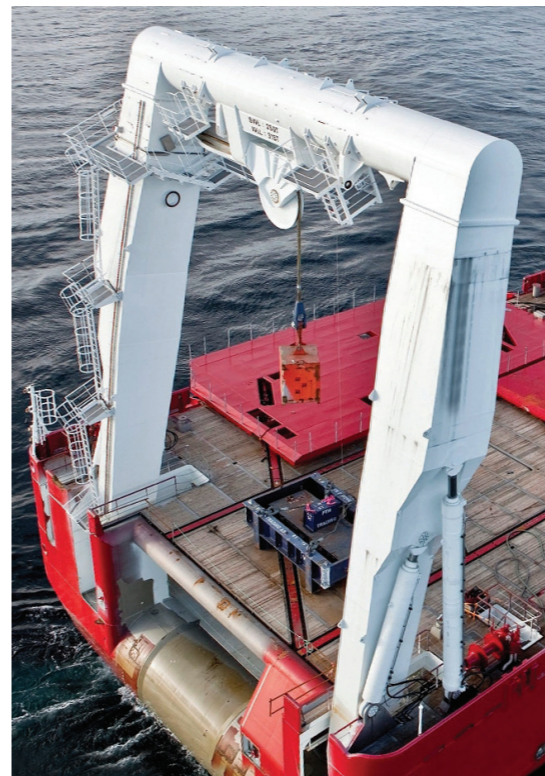

A-frames are mobile lifting systems which are usually installed on the stern of the ship.

An A-frame consists of two moving supports which are mounted on the edge of the ship's deck and are connected at the top by a cross member. There is a winch or pulley in the middle of the cross member.

The supports can pivot outboard or inboard by means of hydraulic cylinders. Objects such as cables, buoys and underwater vehicles can thus be loaded and unloaded by the winch, and underwater work can be facilitated.

The strokes may be up to 7,000 mm for an operating pressure of 350 bar.

- **Cylinder 550/220 – stroke 3,100 mm**

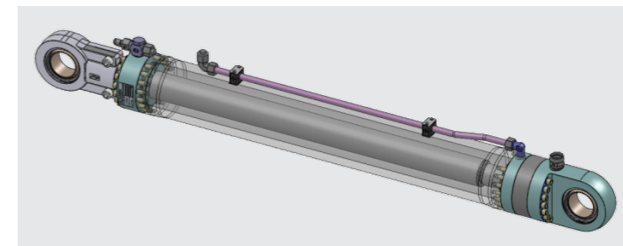

### RO-RO Ships (Roll-On/Roll-Off)



RO-RO ships transport cargo using a roll-on / roll-off method, i.e. the load is rolled or driven onto navigable ship decks. This can be vehicles, such as cars, lorries, buses or entire trains, as well as standardised loading units (containers) and swap bodies.

RO-RO ships are predominantly used as ferries, freighters and cruise ships.

Hatches on the bow, side or stern are used for loading and unloading. Hydraulic cylinders are used when opening and closing the loading hatches and also when raising and lowering the ramps.

# Technical Information

## Requirements for the Perfect Cylinders

### Environment/Conditions

	Seawater air / saltwater air	<b>Class 1</b>
	On deck: Spray water, seawater mist / saltwater mist	<b>Class 2</b>
	Water surface and underwater	<b>Class 3</b>

### Our Suggestion for Bar Stock and Coating

	- Carbon steel with 40/40 µm nickel/chrome - Carbon steel with single-layer HVOF coating	<b>Class 1</b>
	- Carbon steel with double-layer HVOF coating - Stainless steel with 60/40 µm nickel/chrome	<b>Class 2</b>
	- Stainless steel (Duplex/1.4462) with 40 µm chrome - Stainless steel with double-layer HVOF coating	<b>Class 3</b>

### Paintwork

The cylinders are painted according to application conditions or regulations and customer-specific requirements.

**We manufacture and supply the perfect surface coating for your requirements**

### Model Code

	<b>HZ - SD - XXX/XXX - XXXX - 0 - XXX - V</b>
<b>Hydraulic cylinder</b>	
SD = Ship differential cylinder	
SG = Ship double rod cylinder	
<b>Piston/rod diameter</b>	
XXX = mm	
<b>Stroke</b>	
XXXX = mm	
<b>End position damping</b>	
0 = None	
1 = Both	
2 = Piston side only	
3 = Rod side only	
<b>Operating pressure</b>	
XXX = bar	
<b>Add-on equipment</b>	
V = Lock	
W = Position measuring system	
A = Others	

### Our Test Process

Hydraulic cylinders not only have to meet technical specifications, but they must also be suited for use in a wide variety of conditions. They can have a great impact on functionality, particularly with respect to the piston rod since it transmits forces, must withstand shocks and impacts, and is attacked by various environmental conditions.

To assess the quality of our piston rod coatings for use in harsh, corrosive and abrasive environments, we have developed a series of standard tests:

- Abrasion test
- Combined corrosion test
- Bend test
- Side load test

#### Note

The information in this brochure relates to the operating conditions and applications described.

For applications and operating conditions not described, please contact the relevant technical department.

Subject to technical modifications.

# Additional HYDAC Solutions

## From Individual Cylinders to Complete Systems

### Accumulators (Accumulator Technology – Catalogue No 30.000)



Bladder, piston and diaphragm accumulators for mobile and stationary applications

HYDAC offers the most comprehensive range of hydraulic accumulators in the world and can therefore provide the optimum accumulator solution for every application. This is thanks to more than 50 years of experience.

We develop components and systems for all types of hydraulic accumulator, including **bladder, piston and diaphragm accumulators, hydraulic dampers and silencers**. These are manufactured and supplied with approval certification in accordance with the pressure equipment directives and laws of the relevant country.

#### Customer benefits

- Decades of experience in development, design and production
- Comprehensive standard range of products
- Customised solutions
- Diverse range of accessories
- Optimal adaptation using HYDAC Accumulator Simulation Program
- Worldwide maintenance and repair

### Accessories (Accessories – Catalogue No 61.000)



Ball valves, clamps, coaxial valves, fluid level gauges etc.

#### To complete your systems:

- Standard fittings (high pressure), also in stainless steel
- Tamper-proof, inductive proximity switches (high pressure-resistant)
- Fluid level sensors
- Temperature switches TSE
- Standard clamp 3015 air/water reservoir clamping bands
- Test point connections
- Quick release couplings
- Special clamps for particle filters

#### Customer benefits

- Single-source supplier for accessory components of proven HYDAC quality
- Standardised products and customised solutions
- Individual development capacity
- Intelligent warehousing and lean logistics
- Individual product development to customer specification

### Sensors (Electronics – Catalogue No 180.000)

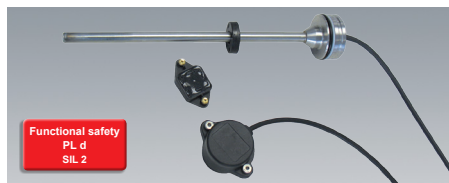

Linear position and distance sensors



Pressure transmitters and pressure switches Sensors for enhanced safety requirements

Our range of sensors includes products for **measuring pressure, temperature, distance, position, level, flow rate, speed, incline, angle as well as contamination and oil condition** (Condition Monitoring).

In addition to products for standard applications, the product portfolio also covers special applications such as potentially explosive atmospheres or applications with increased functional safety.

#### Customer benefits

- The sensors are available with a variety of output signals, electrical connectors and fluid port connection options
- Robust design
- ECE type approval
- Certification for potentially explosive atmospheres (ATEX)
- Separate product range specially for applications with increased functional safety (SIL 2, SIL 3, PL c, PL d)

### Fluid Conditioning Systems (Filter Systems – Catalogue No 79.000)



Mobile and stationary fluid conditioning systems

**Stationary filter systems** to remove solid particles offline (with or without integrated fluid sensors), easy to retrofit on systems.

To provide flexible servicing, there are **mobile filter systems** for filtering, dewatering, degassing and conditioning operating fluids:

- Portable filtration units
- Mobile filtration units

#### Customer benefits

- Improved service life for components and system filters
- Greater system availability
- Longer oil change intervals
- Reduction in the Life Cycle Cost
- Flexible use due to mobile filter systems
- Optional fluid sensors for monitoring and measuring

### Hydraulic Systems

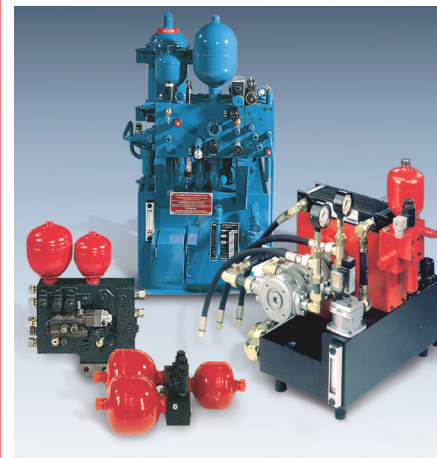

Involve us early on in your planning or design phase: with over 50 years of experience and the expertise of our industry and product specialists, together we can quickly and effectively develop economical solutions.

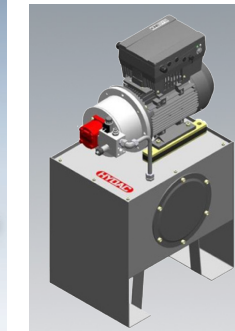

#### Customer benefits

- Customer involvement from development through to commissioning
- Energy-efficient design
- Resource-efficient solutions
- Considers overall Life Cycle Costs
- Modern drive technologies
- Industry 4.0
- International certifications
- Worldwide service

### Condition Monitoring, Teleservice (Condition Monitoring – Catalogue No 10.122)

Constantly growing demands for operational availability, reduction in downtime, and detailed load and service management (economy, wear & tear, service, warranty) require innovative monitoring, service and control concepts. A variety of sensors provides the ideal basis for the development of such integrated system solutions.

- Oil condition, e.g. ageing or mixing with other fluids, can be determined on the basis of the saturation level, temperature, change in electrical conductivity and change in dielectric constant (HYDACLAB®)
- Saturation level (AS)
- Particle contamination (CS)
- Pressure (HDA)
- Flow rate (EVS)
- Fluid level (ENS, HNT)

When used in conjunction with the Portable Data Recorders of the HMG series, this data can be displayed and analysed to supplement the electronics of the system (servicing).

